

AUTOMATED AQUAPONICS: A SURVEY

S. Nivetha, P. Sivanesan and C. Mercy Amrita

College of Fisheries Engineering, Tamil Nadu Dr. J. Jayalalitha Fisheries University,
Nagapattinam, Tamil Nadu, India
E-mail: nivi27699@gmail.com

Abstract: Aquaponics is a mixture of aquaculture and hydroponics. Aquaculture Wastes are used as nutrients by the plants, then the water is recirculated to hydroponics system. Problems will arise in aquaponics system, if any change takes place in water Quality. So, it is important to maintain water quality parameters (Temperature, pH, Ammonia, DO, flowrate) at optimum levels. Any significant change in these parameters, may lead to the death of fishes. Operations of aquaponics system are often difficult, because continuous monitoring is required for healthy growth of plant and fishes. Manually doing this, can be difficult and tiring. Manual testing methods of these parameters, are less accurate and costly. So, there is a need to develop smart system for monitoring and control the automated process of an aquaponics system. This survey helps to know various traditional and automated testing of aquaponics system. This survey will pay the way for researchers to understand the advantages and disadvantages of automated aquaponics system.

Keywords: Aquaponics, Automation, Internet of things, Monitoring, Sensors, Graphical user interface, Data acquisition, Real time systems.

1. Introduction

Aquaponics system links recirculating aquaculture with hydroponics. In aquaponics, highly nutrient effluents from culture tank functions as a fertilizer for hydroponics system. Normally, these nutrients will build up to toxic levels within the fish tanks. But instead of building the toxic level, they function as a liquid fertilizer which will help the growth of plants [1]. The Internet of Things is a worldwide network of machines and devices, which is capable of interacting with each other by in own [2]. Internet of Things (IoT) technology is capable of providing remote, continuous, and real-time informations on a graphical user interface (GUI), by using smart sensors [3]. In Automated Aquaponic system, microcontroller sends measured parameters to a web to store the datas. Then, received data is processed and corresponding actuator is triggered to sustain the optimum level of environmental parameters. All informations are showed in a mobile app or web application, which allow the user to access the real-time data, and manual controls of the actuators. This automated system can run the control parts (actuators) automatically as a results of changes in sensor parameters [4].

The remainder of the paper is organized as follows. Section 2 presents the need to maintain water quality of aquaponics system and Traditional testing methods of water quality parameters. In section 3, we present the automated aquaponics technique and Section 4 gives inference of water quality testing methods. Section 5 concludes the paper and highlights the parameter need to be considered while planning the automated aquaponics system.

2. Need to maintain water quality

For a healthy and productive aquaponics system, maintaining a good balance between optimum water quality parameters of fish, nitrifying bacteria, and plants is important. By monitoring important water quality parameters (DO, pH, TAN and temperature) regularly, abnormalities can be resolved timely to prevent the losses in productivity. In Tilapia aquaponics system, temperature should be maintained between 27⁰C to 29⁰C. Optimum pH level is 7 and Dissolved oxygen should be maintained above 5ppm. TAN concentration should be maintained below 1ppm.

2.1. Traditional testing methods for aquaponics system

In start-up aquaponics systems, water quality parameters must be tested daily, in order to resolve the abnormalities quickly. Once the nutrient cycles are balanced, weekly testings are sufficient.

Simple chemical titration or color change test kits are available to test essential water quality parameters like pH, Ammonia, TAN, DO, which are reasonably priced. For more accurate measurements, many companies provide digital meters for measuring pH, DO and Temperature [5].

2.1.1. Measurement of temperature

Temperature is a critical factor which affects other water quality parameters such as dissolved oxygen, pH, salinity and toxicity of ammonia. Temperature is measured on a linear scale of degrees Celsius or degrees Fahrenheit. Portable thermometer is mostly used for measuring the temperature of water manually. When water temperature drops below 21⁰C, growth of tilapia reduces dramatically and the incidence of disease increases.

2.1.2. Measurement of Dissolved oxygen using Winkler's titration method

In this method, manganese sulphate and alkali iodide are added to the water sample. Then the bottle is stoppered and sample is mixed well. If there any presence oxygen in water sample, it will form orange –brown precipitate. The formed precipitates are dissolved by adding sulphuric acid and water sample. Now Oxygen is mixed with above chemicals and it is fixed. Then starch solution is added to sample which turns the sample blue For the final indication of

neutralization. To determine the DO, oxygen fixed water sample is titrated against sodium thiosulfate to a pale straw yellow color, for neutralization of acid. This titration shows that amount of sodium thiosulfate is proportional to concentration of DO. In this titration, each ml of sodium thiosulfate equals to 1ppm of dissolved oxygen [6].

2.1.3. Measurement of pH

pH is measured by using potentiometry method. In this method, the apparatus consists of Potentiometer, temperature compensating device, glass and reference electrodes. A reference electrode is coupled with glass electrode and both electrodes are incorporated into a single probe. In the glass electrode HCl is placed inside a thin walled glass bulb, whose outer layer will become swollen layer, when dipped in water. Then, there is a ion exchange takes place between swollen layer and H⁺ ions. pH meter measures the difference in emf developed by the glass electrode, which is calibrated to the pH reading directly [7].

2.1.4. Measurement of Ammonia using UV visible spectrophotometer

UV visible spectrophotometer and ammonia test kit are used for the measurement of Ammonia, nitrite and nitrate. In UV visible spectrophotometer method, Ammonia reacts with the Nessler reagent ($K_2[HgI_4]$) and forms a color yellow. It can be measured by spectrophotometer at 430 nm and proportional to the concentration of ammonia. Potassium sodium tartrate is added to stops the cloudiness of the Nessler reagent in water. Total ammonia nitrogen (TAN) is measured by commercially available ammonia test kits [7].

However, it is very difficult to measure and control these water quality parameters manually. Also, continuous monitoring of aquaponics system is necessary for healthy growth of plant and fishes. So, Internet of Things is used to develop an Automatic system, which can monitor and control the aquaponics system by integrating various sensors, Actuators with microcontroller.

3. Automated testing method for aquaponics system

The main objective of an automated aquaponics system is to maintain and control various parameters of an aquaponics system by interconnecting various sensors and actuators with microcontroller to increase productivity.

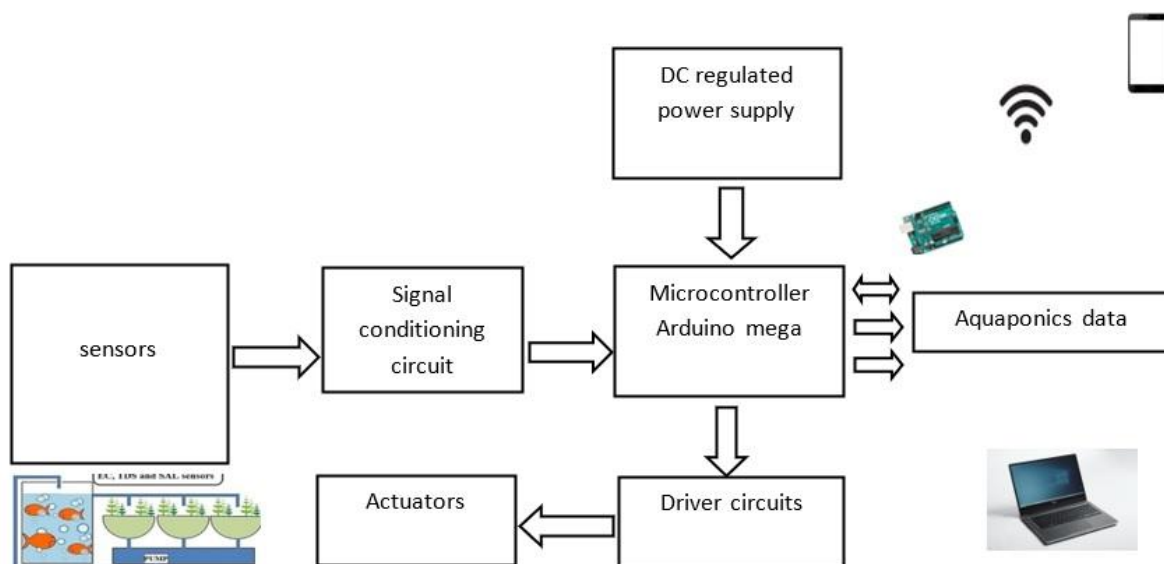

Fig.1. Block diagram of the aquaponics control and monitoring [8].

In automated aquaponic system, temperature, pH, DO, Ammonia, flow rate and light sensors are fitted in aquaponics system for data acquisition. This system accurately and automatically transmits the datas of temperature, pH, DO, ammonia, flow rate, and light to WRT node in real time. Then, these datas are safely stored in cloud storage. Sensors and actuators are connected with microcontroller (Arduino or Raspberry Pi). Microcontroller processes these datas and activates the rectification unit i.e. corresponding actuator (Water heater, LED grow light, secondary water pump and Fish feeder), if any problem arise in the system. For example, the system will alert the user, and turn on water heater, if water temperature falls below optimum level. concurrently, system will send out alert notifications in the forms of email, SMS and record the abnormal condition in the database. Aquaponics system will turn off the water heater and alarm automatically, once water temperature returns to optimum level. Then, the user will be notified with updated information and the system will record the recovery event in the database. Mobile and web applications are created on Raspberry Pi and Android platforms respectively, to give real time system datas to the end users. Users can also control the system through these applications. A camera module also used for the live video streaming of the aquaponics system [9] to [13].

4. Inference

Table 2 compares traditional and automated methods, which are used to measure water quality parameters.

Parameters	Traditional testing method	Automated testing method
Temperature	Portable thermometer	LM35 (or) DHT11 sensor

Dissolved oxygen	Winkler's titration method	Dissolved oxygen probe interfaced with electronic control system
pH	pH meter (or) lab testing	PHE-45P sensor
Ammonia	UV visible spectrophotometer	Ammonia sensor

Table 1: comparison between traditional and automated testing methods

Traditional testing methods are time consuming and not accurate at all times due to human error, hence it is less reliable. But, automated test is more reliable, as it is performed by sensors and it is significantly faster than traditional methods.

5. Conclusion

By the implementation of large-scale Smart Aquaponics system, we can minimize operating cost and labours significantly, while extending the production and profitability. The essential water quality parameters which increase the fish survival rate should be monitored. The live data streaming is needed for control of aquaponics system and the system should be designed with less power, low bandwidth with connector. In future the essential complex water quality parameters need to be analysed with IoT techniques and real time data should be collected and control with actuators. The system should be designed for healthy fish growth and organic plant growth. The automated aquaponics system must focus on low power, less bandwidth Wi-Fi, secured cloud for data storage and retrieval. In future, aquaponics will emerge as a bio-integrated and sustainable food production system.

References

- [1] Diver, S., & Rinehart, L. (2000). *Aquaponics-Integration of hydroponics with aquaculture*. Attra.
- [2] Lee, I., & Lee, K. (2015). The Internet of Things (IoT): Applications, investments, and challenges for enterprises. *Business Horizons*, 58(4), 431-440.
- [3] Abraham, S., Shahbazian, A., Dao, K., Tran, H., & Thompson, P. (2017, October). An Internet of Things (IoT)-based aquaponics facility. In *2017 IEEE Global Humanitarian Technology Conference (GHTC)* (pp. 1-1). IEEE.
- [4] Mandap, J.P., Sze, D., Reyes, G.N., Dumlao, S.M., Reyes, R., & Chung, W.Y.D. (2018, October). Aquaponics ph level, temperature, and dissolved oxygen monitoring and control system using raspberry pi as network backbone. In *TENCON 2018-2018 IEEE Region 10 Conference* (pp. 1381-1386). IEEE.

- [5] Sallenave, R. (2016). *Important water quality parameters in aquaponics systems*. NM State University, Cooperative Extension Service, College of Agricultural, Consumer and Environmental Sciences.
- [6] Carpenter, J.H. (2006). Determination of dissolved oxygen by Winkler Titration. *Environmental Chemistry of Boston Harbor, (1888)*, 1-10.
- [7] Amrita, C.M., & Babiyola, D. (2018). Analysing the water quality parameters from traditional to modern methods in aquaculture. *International Journal of Science, Environment and Technology*, 7(6), 1954-1961.
- [8] Nagayo, A.M., Cesar, M., Eugene, V., Raad, K.S., & Rodrigo, S. (2017, July). An automated solar-powered aquaponics system towards agricultural sustainability in the sultanate of oman. In *2017 IEEE International Conference on Smart Grid and Smart Cities (ICSGSC)* (pp. 42-49). IEEE.
- [9] Kyaw, T.Y., & Ng, A.K. (2017). Smart aquaponics system for urban farming. *Energy procedia*, 143, 342-347.
- [10] Mamatha, M.N., & Namratha, S.N. (2017, August). Design & implementation of indoor farming using automated aquaponics system. In *2017 IEEE International Conference on Smart Technologies and Management for Computing, Communication, Controls, Energy and Materials (ICSTM)* (pp. 396-401). IEEE.
- [11] Manju, M., Karthik, V., Hariharan, S., & Sreekar, B. (2017, March). Real time monitoring of the environmental parameters of an aquaponic system based on Internet of Things. In *2017 Third International Conference on Science Technology Engineering & Management (ICONSTEM)* (pp. 943-948). IEEE.
- [12] Wang, D., Zhao, J., Huang, L., & Xu, D. (2015, July). Design of a smart monitoring and control system for aquaponics based on Open Wrt. In *5th International Conference on Information Engineering for Mechanics and Materials*. Atlantis Press.
- [13] Yanes, A.R., Martinez, P., & Ahmad, R. (2020). Towards automated aquaponics: A review on monitoring, IoT, and smart systems. *Journal of Cleaner Production*, 121571.